

Motor Driver(5-Phase stepping motor driver) KR-A5M

M A N U A L

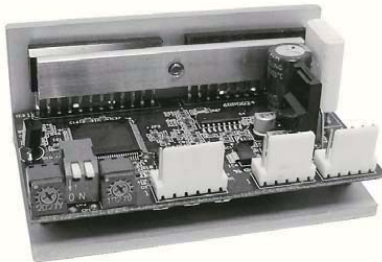

Thank you very much for selecting Technodrive products.
For your safety, please read the following before using.

Caution for your safety

※Please keep these instructions and review them before using this unit.

※Please observe the cautions that follow;

Warning Serious injury may result if instructions are not followed.

Caution Product may be damaged, or injury may result if instructions are not followed.

※The following is an explanation of the symbols used in the operation manual.

⚠caution: Injury or danger may occur under special conditions.

Warning

- In case of using this unit with machinery(Nuclear power control, medical equipment, vehicle, train, airplane, combustion apparatus, entertainment or safety device etc), it is required to install fail-safe device, or contact us for information on type required.**
It may cause serious human injury or a fire, property.
- Installation, connection, operation, control, maintenance should be carried out by person who has been qualified.**
It may cause a fire, human injury or give an electric shock.
- Please use DC power with reinforced insulating the primary and secondary part for the DC power product.**
It may give an electric shock.
- Please install this unit after consider countplan against power failure.**
It may cause human injury or damage to product by releasing holding torque of motor.
- Do not use this unit outdoors or place where there are explosiveness, flammable, corrosive gas, water and frequent vibration etc.**
It may cause a fire or give an electric shock.
- Do not disassemble or modify this unit. Please contact us if it required.**
It may cause a fire, give an electric shock or damage to product.
- Please install protection equipment on board type product.**
It may cause a fire.

Caution

- Power input voltage must be used within rating specification and power line should be over than AWG NO. 18(0.75mm²).**
It may cause a fire or give an electric shock.
- Please check the connection before power.**
It may cause a fire or give an electric shock.
- Please turn off when power failure occurred.**
It may cause human injury or damage to product due to sudden movement by recovering from power failure.
- Do not touch during the operation or after a while of operation.**
It may cause a burn due to high temperature in surface.
- The emergency stop should be enabled during the operation.**
It may cause human injury or damage to product.
- Please apply power after checking control input signal.**
It may cause human injury or damage to product by sudden movement.
- Do not turn on the HOLD OFF signal input while it is maintaining vertical position.**
It may cause human injury or damage to product by releasing holding torque of motor.
- Please install a safety device when need to remain the vertical position after turn off the power.**
It may cause human injury or damage to product by releasing holding torque of motor.
- Please check if HOLD OFF signal input is ON when need to set the output manually.**
It may cause human injury by sudden movement.
- Please stop this unit when mechanical problem is occurred.**
It may cause a fire or human injury.
- Do not touch the terminal when during the insulation dielectric strength test or insulation resistance measurement.**
It may give an electric shock.
- Please observe rating specification.**
It may cause a fire, give an electric shock or damage to product.
- In cleaning the unit, do not use water or an oil-based detergent.**
It may cause a fire or give an electric shock.
- Please separate as industrial waste when disuse this unit.**

※ The above specifications are changeable at anytime without notice.

Features

- Full/Half step
- Bipolar constant current pentagon drive method.
- STOP/RUN current adjustable
- Photocoupler input insulation method to minimize the effects from external noise.
- Power supply : 20—35VDC

Specifications

Model	KR—A5M	
Power supply	20—35VDC(3A Max.)	
RUN current	0.5~1.5A/Phase	
Drive method	Bipolar constant current pentagon drive	
Resolution(Rotating angle)	× 1(0.72°), × 2(0.36°)	
CW/CCW Input pulse	Pulse width	Min. 0.5μs
	Pulse interval	Min. 0.5μs
	Rising/Falling time	Max. 1μs
	Frequency	Max. 50kpps
	Voltage	High:4—8VDC, Low:0—0.5VDC
Ambient temperature	0~40°C(at non-freezing status)	
Ambient humidity	35~85%RH(at non-dew status)	
Unit weight	Approx. 74g	

※ There is torque difference by input power.

Dimensions

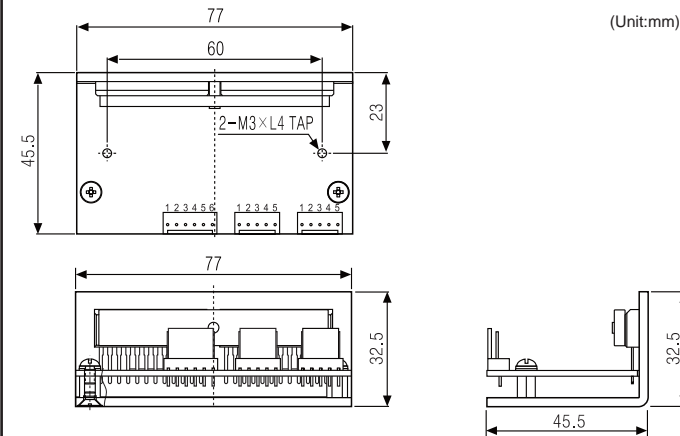

※ Accessory connector specification (manufacturer: MOLEX)

	Model	Quantity
5-pin power connector	5051-05	1
5-pin motor connector	5051-05	1
6-pin signal connector	5051-06	1
Connector pin	5159TL	16

Time charts

◎ CW / CCW Input(CW : Clockwise direction from the front view of shaft)

● 2 Pulse type

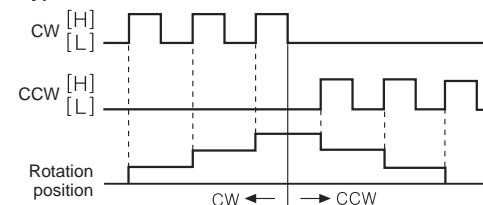

● 1 Pulse type

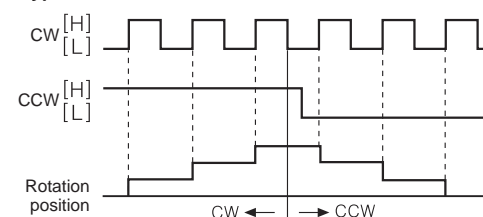

Note

When using 2 pulse input method, do not input CW and CCW signal at the same time. When one of the CW and CCW signals is [ON], it may not be worked normally.

Connections

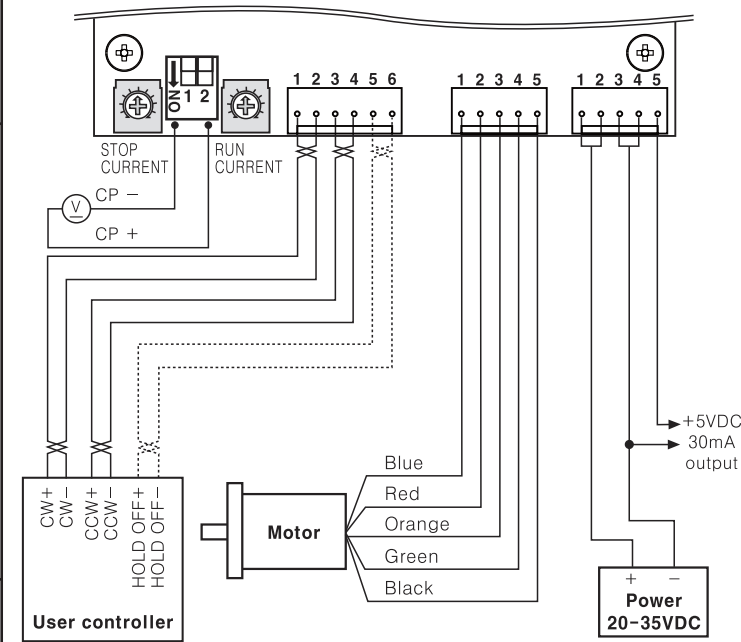

Input·Output diagram

<KR—A5M Driver inner circuit>

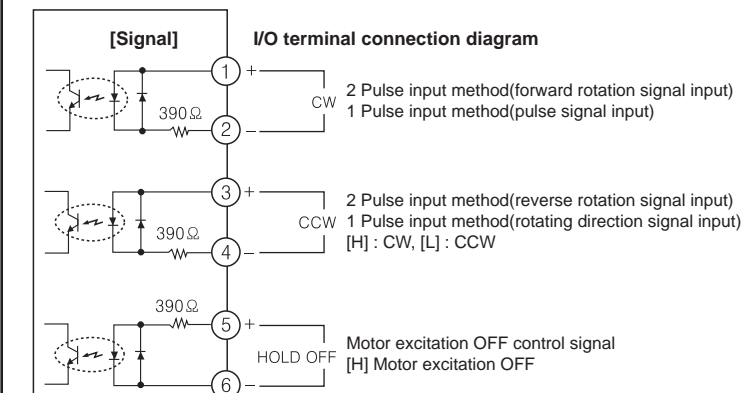

Motor connection diagram and power supply

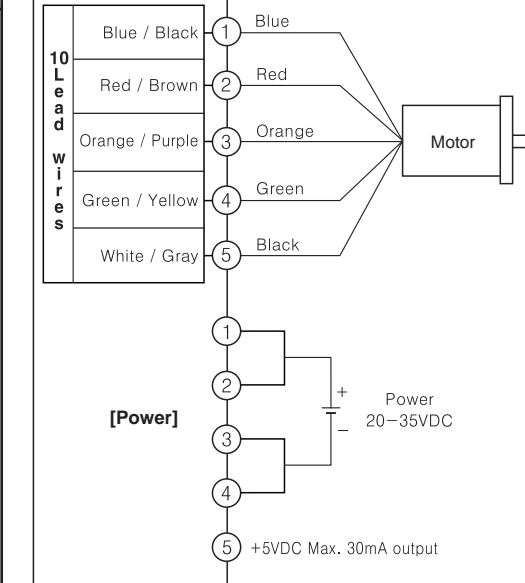

Note

Add external resistor when power for pulse from the external of the unit exceeds +5VDC.

Selectable function switch

● Select input method

OFF	1	1 Pulse input method
ON	2	2 Pulse input method

● Select resolution(rotation angle)

OFF	2	× 1(0.72°)
ON	1	× 2(0.36°)

Setting RUN current

- RUN current is phase current provided for motor when the motor runs.
 - Set the RUN current SV within the rated current of motor. (When RUN current SV is higher, it may cause heat stress on the unit. When RUN current SV is lower, it may decrease running torque.)
 - To change the RUN current, connect the CP- to the(-) terminal of the voltmeter and the CP+ to the (+) terminal of the voltmeter then adjust RUN current switch.
 - Phase current change :
Setting current(A) = $\frac{\text{CP measurement voltage(V)}}{2}$
- Note) RUN current should be changed during the operating of motor.

Setting STOP current

- STOP current is phase current provided for motor when the motor stops.
 - STOP current VR SV is the percentage of RUN current SV.(When STOP current SV is higher, it may cause heat stress on the unit. When STOP current SV is lower, it may decrease stop torque.)
 - E) After setting 1.0A for RUN current then put STOP current adjuster at 50%, STOP current will be 0.5A.
- Note) STOP current should be changed during the motor stops.

HOLD OFF function

- HOLD OFF is [H], the excitation is released, because current provided to each phase is cut off.
- HOLD OFF is [L], the excitation is in a normal status.
- It rotates motor axis by external force or is used for manual positioning.
- Input H/L means ON/OFF of photocoupler in a circuit.

Caution for using

- Caution for signal input**
 - Do not input CW, CCW signal at the same time in 2 Pulse input method. It may not work properly if another signal is supplied when one of them is ON.
 - In case, the signal input supply is higher than rated supply expressed on the specification, please connect the additional resistor to external part.
- Caution for supplying power**
 - In order to increase heat protection efficiency, keep the heat sink as close as possible to metal panel and keep it well-ventilated.
 - The current value indicated on power supply is the max. input of driver.
 - Please check the polarity of power before using.**
- Caution for wiring**
 - Use Twist pair(Over 0.2mm²) for the signal wire should be shorter than 2m.
 - Please use an electric wire is thicker than the motor lead when product the motor wire connection.
- Caution for installation**
 - Excessive heat generation may occur on Driver. Keep the heat sink under 80°C when installing the unit. (In case it is over 80°C, forcible cooling shall be required.)
- Installation environment**
 - It shall be used indoor
 - Pollution Degree 2
 - Altitude Max. 2000m
 - Installation Category II

※ It may cause malfunction if above instructions are not followed.

Technodrive Co., Ltd.
TECHNO DRIVE
101, New Well Ikuta Bldg.,
26-28, Mita 1-chome, Tama-ku, Kawasaki-shi, Kanagawa Pref., 214-0034, Japan
TEL. +81-44-935-0072 FAX. +81-44-935-0708
URL. <http://www.technodrive.com>
E-Mail. mail@technodrive.com